

Straight guide pillar	3.03
Demountable guide pillar with fixing clamps	3.04
Demountable guide pillar with central fixing	3.05
Demountable steel guide bush	3.06
Demountable bronze-plated guide bush	3.07
Straight sleeve ball bearing bush	3.08
Demountable ball bearing bush	3.09
Stripper plate - demountable ball bearing bushes	3.10
Type 3 ball bearing cage	3.11
Type 1 and 2 ball bearing cage	3.12 3.13
Demountable steel block for pillar or bush	3.14 3.15
Assembly instructions	3.16 3.17
Guide pillar selection - Type 1	3.18
Guide pillar selection - Type 2	3.20
Guide pillar selection - Type 3	3.24
Accessories	3.25



Case-hardened and tempered to 60 - 64 HRC

Ordering example:

Pillar D1=30 L=160

Please state: **P10.030.160**

To be used with:

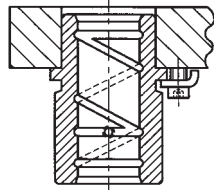

Steel bush
Bronze-plated bush

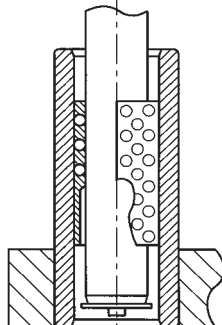

Flanged bearing bush
Ball bearing cage

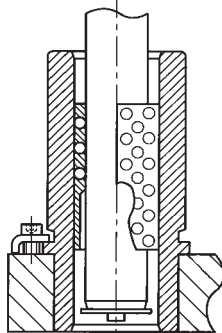

Demountable bush
Ball bearing cage

Examples:

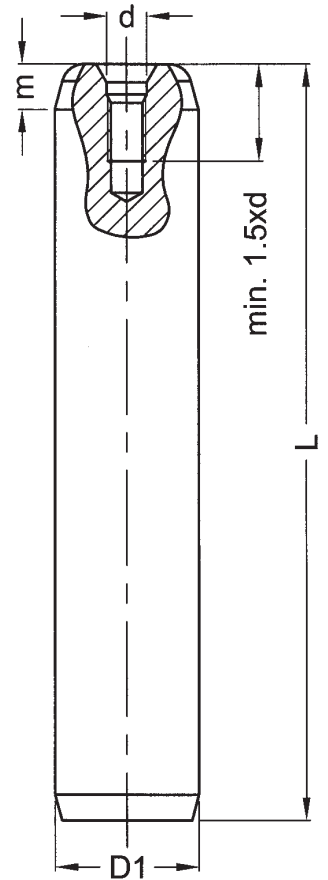
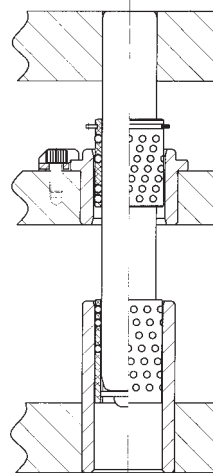
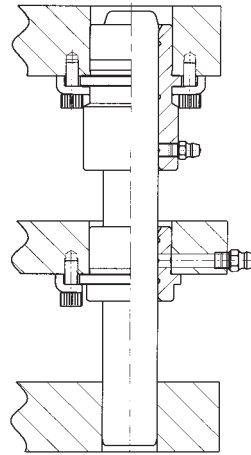

D ₁	19	20	24	25	30	32	38	40	48	50	63	80
d	M5		M6		M8		M10		M12		M16	M20
m	6		8		8		8		8		8	8
L	REFERENCES											
100	P10.019.100	P10.020.100	P10.024.100	P10.025.100								
110	P10.019.110	P10.020.110	P10.024.110	P10.025.110	P10.030.110	P10.032.110						
125	P10.019.125	P10.020.125	P10.024.125	P10.025.125	P10.030.125	P10.032.125	P10.038.125	P10.040.125				
140	P10.019.140	P10.020.140	P10.024.140	P10.025.140	P10.030.140	P10.032.140	P10.038.140	P10.040.140				
160	P10.019.160	P10.020.160	P10.024.160	P10.025.160	P10.030.160	P10.032.160	P10.038.160	P10.040.160	P10.048.160	P10.050.160		
180	P10.019.180	P10.020.180	P10.024.180	P10.025.180	P10.030.180	P10.032.180	P10.038.180	P10.040.180	P10.048.180	P10.050.180		
200	P10.019.200	P10.020.200	P10.024.200	P10.025.200	P10.030.200	P10.032.200	P10.038.200	P10.040.200	P10.048.200	P10.050.200	P10.063.200	
220			P10.024.220	P10.025.220	P10.030.220	P10.032.220	P10.038.220	P10.040.220	P10.048.220	P10.050.220	P10.063.220	
250			P10.024.250	P10.025.250	P10.030.250	P10.032.250	P10.038.250	P10.040.250	P10.048.250	P10.050.250	P10.063.250	
280			P10.024.280	P10.025.280	P10.030.280	P10.032.280	P10.038.280	P10.040.280	P10.048.280	P10.050.280	P10.063.280	P10.080.280
315					P10.030.315	P10.032.315	P10.038.315	P10.040.315	P10.048.315	P10.050.315	P10.063.315	P10.080.315
355							P10.038.355	P10.040.355	P10.048.355	P10.050.355	P10.063.355	P10.080.355
400									P10.048.400	P10.050.400	P10.063.400	P10.080.400
450									P10.048.450	P10.050.450	P10.063.450	P10.080.450
500											P10.063.500	P10.080.500



Case-hardened and tempered to 60 - 64 HRC

Supplied with mounting clamps and screws

Ordering example:

Pillar D1=30 F=160

Please state: **P21.030.160**

To be used with:

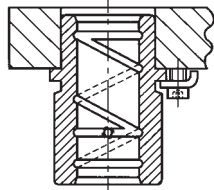

Steel bush
Bronze-plated bush

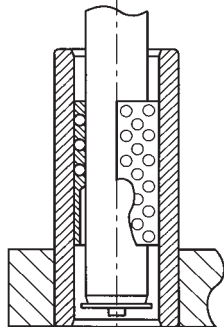

Flanged bearing bush
Ball bearing cage

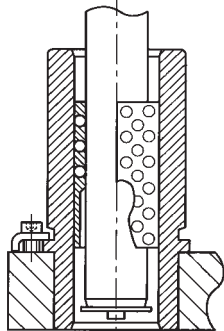

Demountable bush
Ball bearing cage

Examples:

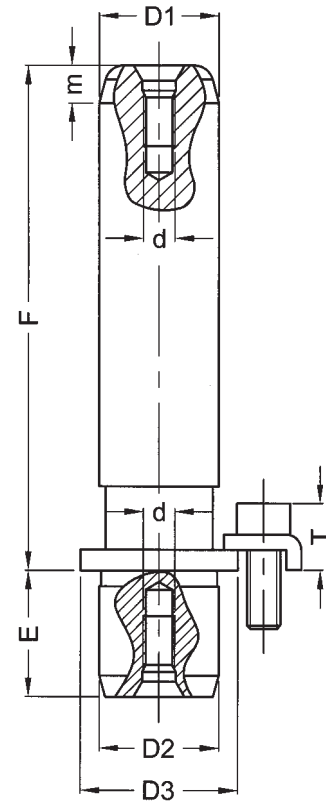
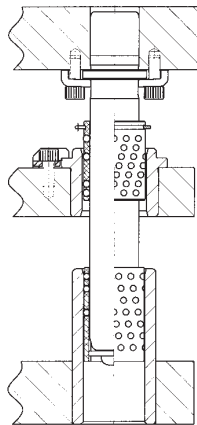
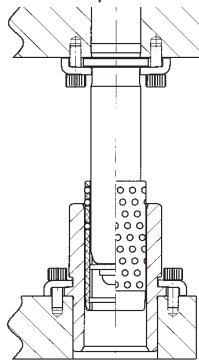

from
Ø19 to 32

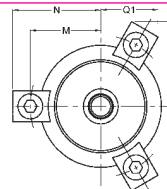

from
Ø38 to 80

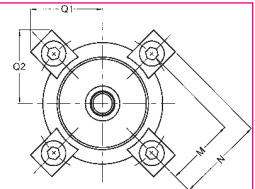

D ₁ =D ₂	19	20	24	25	30	32	38	40	48	50	63	80
D ₃	25		32		40		50		63		76	93
E	20		25		32		40		45		50	60
d	M5		M6		M8		M10		M12		M16	M20
m	6		8		8		8		8		8	8
Qty	3		3		3		4		4		4	4
Clamp	B01.005.000		B01.006.000		B01.006.000		B01.008.000		B01.008.000		B01.008.000	
Screw	M5 x12		M6 x16		M6 x16		M8 x20		M8 x20		M8 x20	
M	16		20,3		24		30		36,5		42,5	
N	22		27,5		31,5		39,3		45,8		51,8	
Q1	16,5		20,6		22,6		33,4		38		42,2	
Q2	22,2		27,8		31,3		38		38		42,2	
T	10,5		14,7		14,7		17,5		17,5		17,5	

REFERENCES

80	P21.019.080	P21.020.080	P21.024.080	P21.025.080								
90	P21.019.090	P21.020.090	P21.024.090	P21.025.090								
100	P21.019.100	P21.020.100	P21.024.100	P21.025.100	P21.030.100	P21.032.100	P21.038.100	P21.040.100				
110	P21.019.110	P21.020.110	P21.024.110	P21.025.110	P21.030.110	P21.032.110	P21.038.110	P21.040.110	P21.048.110	P21.050.110		
125	P21.019.125	P21.020.125	P21.024.125	P21.025.125	P21.030.125	P21.032.125	P21.038.125	P21.040.125	P21.048.125	P21.050.125	P21.063.125	
140	P21.019.140	P21.020.140	P21.024.140	P21.025.140	P21.030.140	P21.032.140	P21.038.140	P21.040.140	P21.048.140	P21.050.140	P21.063.140	
160	P21.019.160	P21.020.160	P21.024.160	P21.025.160	P21.030.160	P21.032.160	P21.038.160	P21.040.160	P21.048.160	P21.050.160	P21.063.160	
180			P21.024.180	P21.025.180	P21.030.180	P21.032.180	P21.038.180	P21.040.180	P21.048.180	P21.050.180	P21.063.180	
200			P21.024.200	P21.025.200	P21.030.200	P21.032.200	P21.038.200	P21.040.200	P21.048.200	P21.050.200	P21.063.200	P21.080.200
220					P21.030.220	P21.032.220	P21.038.220	P21.040.220	P21.048.220	P21.050.220	P21.063.220	P21.080.220
250					P21.030.250	P21.032.250	P21.038.250	P21.040.250	P21.048.250	P21.050.250	P21.063.250	P21.080.250
280					P21.030.280	P21.032.280	P21.038.280	P21.040.280	P21.048.280	P21.050.280	P21.063.280	P21.080.280
315									P21.048.315	P21.050.315	P21.063.315	P21.080.315
355									P21.048.355	P21.050.355	P21.063.355	P21.080.355
400									P21.048.400	P21.050.400	P21.063.400	P21.080.400



Case-hardened and tempered to 60 - 64 HRC

Supplied with washer.

Ordering example:

Pillar D1=30 F=160

Please state: **P22.030.160**

To be used with:

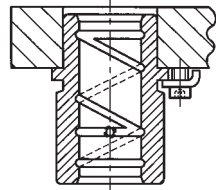

Steel bush
Bronze-plated bush

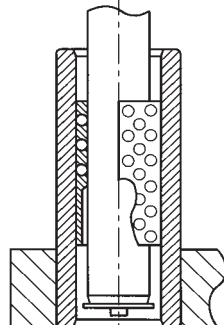

Flanged bearing bush
Ball bearing cage

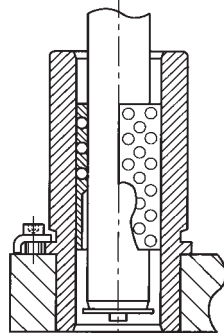

Demountable bush
Ball bearing cage

Examples

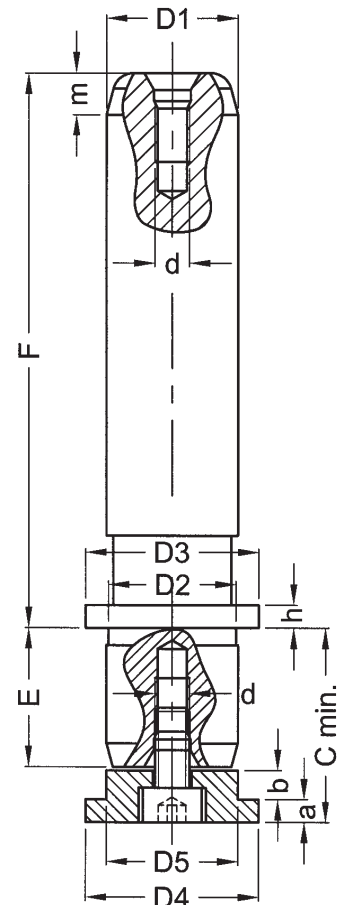
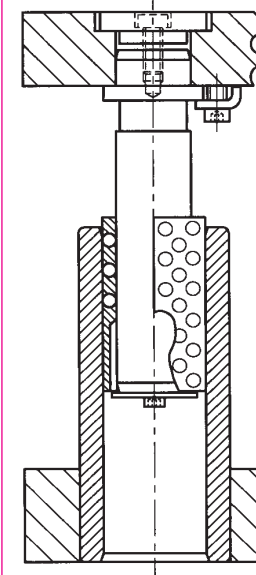
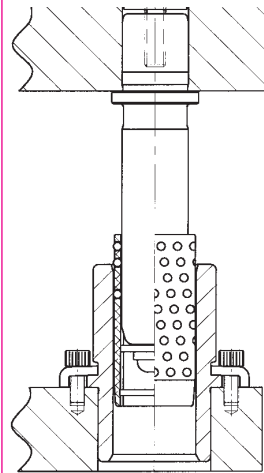

Please note: The minimum dimension C_{min} must correspond to the min. plate thickness

D1=D2	19	20	24	25	30	32	38	40	48	50	63	80
D3		25		32		40		50		63		93
D4		25		32		40		50		63		93
D5		19		24		30		38		48		80
E		20		25		32		40		45		60
d		M5		M6		M8		M10		M12		M20
m		6		8		8		8		8		8
a		3,3		5		5		5		5		5
b		4,2		4		7		10		13		25
C min.		28		35		45		56		64		91
Washer		P02.020.000		P02.025.000		P02.032.000		P02.040.000		P02.050.000		P02.080.000
h		3,3		5		5		5		5		5
F												
REFERENCES												
80	P22.019.080	P22.020.080	P22.024.080	P22.025.080								
90	P22.019.090	P22.020.090	P22.024.090	P22.025.090								
100	P22.019.100	P22.020.100	P22.024.100	P22.025.100	P22.030.100	P22.032.100	P22.038.100	P22.040.100				
110	P22.019.110	P22.020.110	P22.024.110	P22.025.110	P22.030.110	P22.032.110	P22.038.110	P22.040.110	P22.048.110	P22.050.110		
125	P22.019.125	P22.020.125	P22.024.125	P22.025.125	P22.030.125	P22.032.125	P22.038.125	P22.040.125	P22.048.125	P22.050.125	P22.063.125	
140	P22.019.140	P22.020.140	P22.024.140	P22.025.140	P22.030.140	P22.032.140	P22.038.140	P22.040.140	P22.048.140	P22.050.140	P22.063.140	
160	P22.019.160	P22.020.160	P22.024.160	P22.025.160	P22.030.160	P22.032.160	P22.038.160	P22.040.160	P22.048.160	P22.050.160	P22.063.160	
180			P22.024.180	P22.025.180	P22.030.180	P22.032.180	P22.038.180	P22.040.180	P22.048.180	P22.050.180	P22.063.180	
200			P22.024.200	P22.025.200	P22.030.200	P22.032.200	P22.038.200	P22.040.200	P22.048.200	P22.050.200	P22.063.200	P22.080.200
220					P22.030.220	P22.032.220	P22.038.220	P22.040.220	P22.048.220	P22.050.220	P22.063.220	P22.080.220
250					P22.030.250	P22.032.250	P22.038.250	P22.040.250	P22.048.250	P22.050.250	P22.063.250	P22.080.250
280					P22.030.280	P22.032.280	P22.038.280	P22.040.280	P22.048.280	P22.050.280	P22.063.280	P22.080.280
315									P22.048.315	P22.050.315	P22.063.315	P22.080.315
355									P22.048.355	P22.050.355	P22.063.355	P22.080.355
400									P22.048.400	P22.050.400	P22.063.400	P22.080.400



DEMOUNTABLE STEEL GUIDE BUSH DEMOUNTABLE BRONZE-PLATED GUIDE BUSH

B10.XXX.XXX
B12.XXX.XXX
B20.XXX.XXX
B22.XXX.XXX



Case-hardened and tempered to 60 - 64 HRC
Supplied with mounting clamps and screws

Ordering example:

Pillar D1=40 F=100

Please state:

B10.040.100: steel

B20.040.100: bronze-plated

To be used with:



Pillar

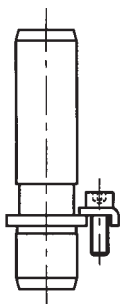

Demountable pillar

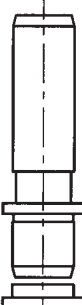

Demountable pillar

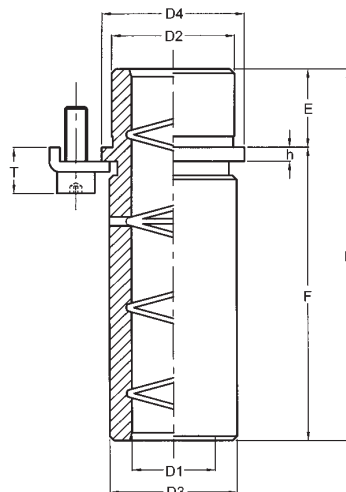

EXTRA-LONG SHOULDER

Steel: **B10.0xx.100**
Bronze-plated: **B20.0xx.100**

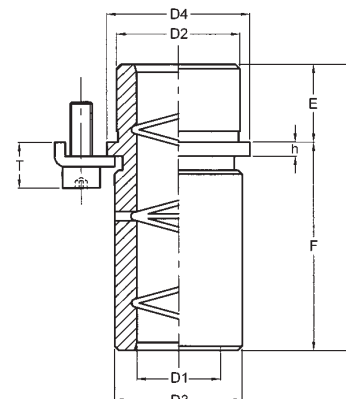

LONG SHOULDER

Steel: **B10.0xx.075**
Bronze-plated: **B20.0xx.075**

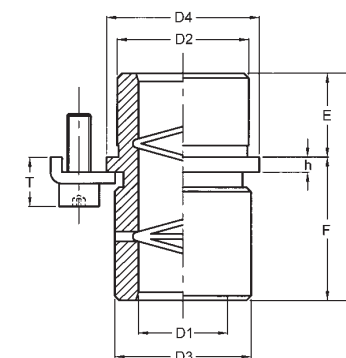

NORMAL SHOULDER

Steel: **B10.0xx.032**
B10.0xx.050

Bronze-plated: **B20.0xx.032**
B20.0xx.050

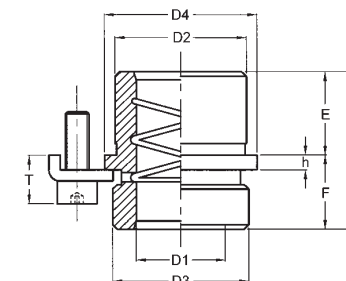

SHORT SHOULDER

Steel: **B10.0xx.016**
B10.0xx.020

Bronze-plated: **B20.0xx.016**
B20.0xx.020

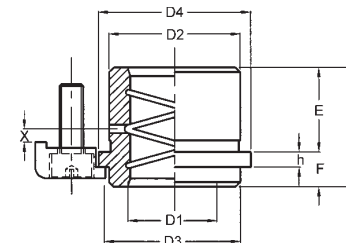

EXTRA-SHORT SHOULDER

Steel: **B12.0xx.010**
B12.0xx.014

Bronze-plated: **B22.0xx.010**
B22.0xx.014

Examples

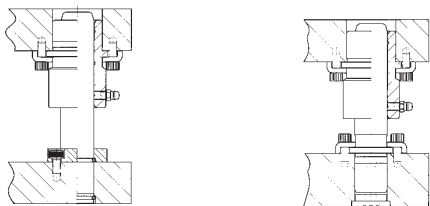

Positions of bush mounting clamps.

For Ø19 to 20

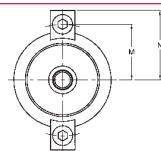

For Ø24 to 32

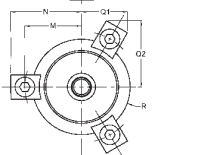

For Ø38 to 80

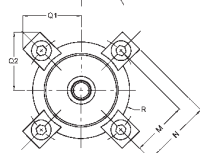



**DEMOUNTABLE STEEL GUIDE BUSH
DEMOUNTABLE
BRONZE-PLATED GUIDE BUSH**

**B10.XXX.XXX
B12.XXX.XXX
B20.XXX.XXX
B22.XXX.XXX**

D ₁	19	20	24	25	30	32	38	40	48	50	63	80
D ₂	28		38		45		54		65		81	100
D ₃	29		42		49		58		70		88	110
D ₄	32,5		47		54		63		75		93	115
E	18		22		25		30		35		48	48
h	3,3		5		5		5		5		5	5
No. of clamps	2		3		3		4		4		4	4
Clamp ref.	B01.005.000		B01.006.000		B01.006.000		B01.008.000		B01.008.000		B01.008.000	B01.008.000
Screw	M5x12		M6x16		M6x16		M8x20		M8x20		M8x20	M8x20
M	19,5		27,5		31		37		43		52	63
N	25,5		35		38,2		46,3		52,3		61,3	72,3
Q1/R	-		24,4/23,5		26/27		30/31,5		33/37,5		37,5/46,5	43/57,5
Q2	-		34,3		37,1		44,1		49,3		57,1	66,6
T	10,5		14,7		14,7		17,5		17,5		17,5	17,5

EXTRA-LONG SHOULDER

D ₁					30	32	38	40	48	50	63	
F					100	100	100	100	100	100	100	
L					125	130	130	130	135	135	148	
Steel ref.					B10.0xx.100	B10.0xx.100	B10.0xx.100	B10.0xx.100	B10.0xx.100	B10.0xx.100	B10.063.100	
Bronze-plated ref.					B20.0xx.100	B20.0xx.100	B20.0xx.100	B20.0xx.100	B20.0xx.100	B20.0xx.100	B20.063.100	

LONG SHOULDER

D ₁			24	25	30	32	38	40	48	50	63	
F			75	75	75	75	75	75	75	75	75	
L			97	100	100	105	105	110	110	110	123	
Steel ref.			B10.0xx.075	B10.0xx.075	B10.0xx.075	B10.0xx.075	B10.0xx.075	B10.0xx.075	B10.0xx.075	B10.0xx.075	B10.063.075	
Bronze-plated ref.			B20.0xx.075	B20.0xx.075	B20.0xx.075	B20.0xx.075	B20.0xx.075	B20.0xx.075	B20.0xx.075	B20.0xx.075	B20.063.075	

NORMAL SHOULDER

D ₁	19	20	24	25	30	32	38	40	48	50	63	80
F	32		50		50		50		50		50	50
L	50		72		75		80		85		98	98
Steel ref.	B10.0xx.032		B10.0xx.050		B10.0xx.050		B10.0xx.050		B10.0xx.050		B10.063.050	B10.080.050
Bronze-plated ref.	B20.0xx.032		B20.0xx.050		B20.0xx.050		B20.0xx.050		B20.0xx.050		B20.063.050	B20.080.050

SHORT SHOULDER

D ₁	19	20	24	25	30	32	38	40	48	50	63	80
F	16		20		20		20		20		20	20
L	34		42		45		50		55		68	68
Steel ref.	B10.0xx.016		B10.0xx.020		B10.0xx.020		B10.0xx.020		B10.0xx.020		B10.063.020	B10.080.020
Bronze-plated ref.	B20.0xx.016		B20.0xx.020		B20.0xx.020		B20.0xx.020		B20.0xx.020		B20.063.020	B20.080.020

EXTRA-SHORT SHOULDER

D ₁	19	20	24	25	30	32	38	40	48	50	63	80
D ₃	29		36		43		50		64		79	99
F	10		10		10		14		14		14	14
E	18		23		30		38		48		61	78
L	28		33		40		52		62		75	92
X	6		6		10		10		20		20	32
Clamp ref.	B01.005.000		B02.006.000		B02.006.000		B02.008.000		B02.008.000		B02.008.000	B02.008.000
Screw	M5x12		M6x12		M6x12		M8x16		M8x16		M8x16	M8x16
M	19,5		30		33,5		40		46		55	66
N	25,5		38		41,5		51,2		57,2		66,7	77,2
Q1/R	-		25,2/23,5		26,9/27		33,7/31,5		36,7/37,5		41,5/46,5	46,7/57,5
Q2	-		36,5		39,5		49,0		54,2		62,5	71,6
Steel ref.	B12.0xx.010		B12.0xx.010		B12.0xx.010		B12.0xx.014		B12.0xx.014		B12.063.014	B12.080.014
Q1/R	B22.0xx.010		B22.0xx.010		B22.0xx.010		B22.0xx.014		B22.0xx.014		B22.063.014	B22.080.014



Made from vacuum-degassed alloy steel

Ordering example:

Pillar D1=30 Lb=110

Please state: **B30.030.110**

To be used with:

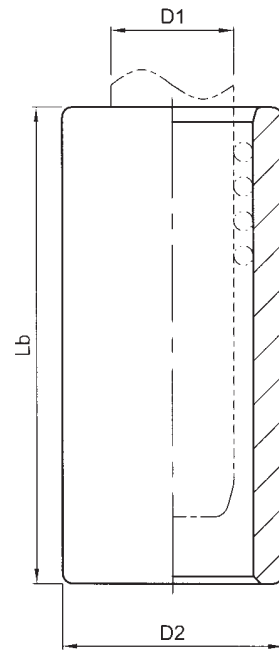
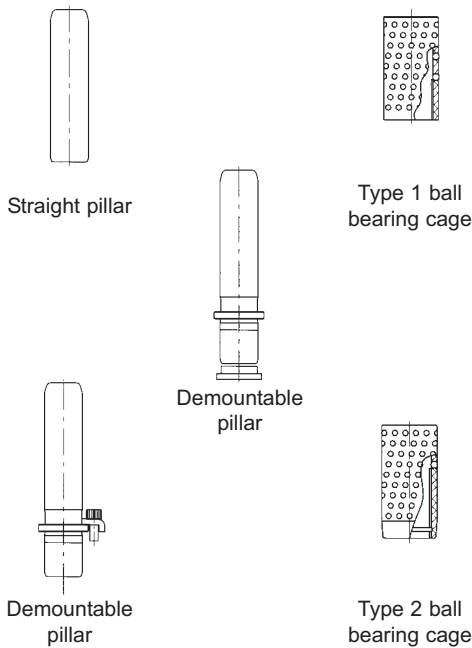

Upon demand

Examples

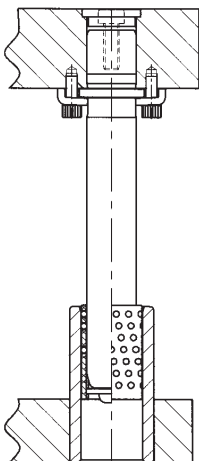
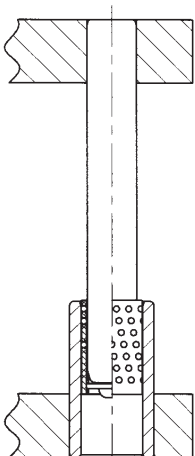

D1	24	25	30	32	38	40	48	50	63	80
D2	45		54		65		81		95	112
Lb	REFERENCES									
65	B30.024.065	B30.025.065								
80	B30.024.080	B30.025.080	B30.030.080	B30.032.080	B30.038.080	B30.040.080				
95	B30.024.095	B30.025.095	B30.030.095	B30.032.095	B30.038.095	B30.040.095				
110	B30.024.110	B30.025.110	B30.030.110	B30.032.110	B30.038.110	B30.040.110	B30.048.110	B30.050.110		
130	B30.024.130	B30.025.130	B30.030.130	B30.032.130	B30.038.130	B30.040.130	B30.048.130	B30.050.130		
150			B30.030.150	B30.032.150	B30.038.150	B30.040.150	B30.048.150	B30.050.150	B30.063.150	B30.080.150
170			B30.030.170	B30.032.170	B30.038.170	B30.040.170	B30.048.170	B30.050.170	B30.063.170	B30.080.170
190					B30.038.190	B30.040.190	B30.048.190	B30.050.190	B30.063.190	B30.080.190
215					B30.038.215	B30.040.215	B30.048.215	B30.050.215	B30.063.215	B30.080.215
240							B30.048.240	B30.050.240	B30.063.240	B30.080.240
265							B30.048.265	B30.050.265	B30.063.265	B30.080.265

ASSEMBLY INSTRUCTIONS

Straight sleeve ball bearing bushes are glued into the plate

1. Degrease with acetone or a similar solvent and thoroughly wipe clean the outer surface of the straight sleeve bush and the inside of the plate bore.
2. Apply a thin layer of Loctite 601 glue to both surfaces.
3. Insert the bush into the hole while turning.
4. Leave to set for the required amount of time (e.g. 4 hours at 22°C)

To select, please refer to pages 3.18 to 3.22



Case-hardened and tempered to 60 - 64 HRC

Supplied with clamps and screws.

Ordering example:

Pillar D1=30 F=80

Please state: **B40.030.080**

To be used with:

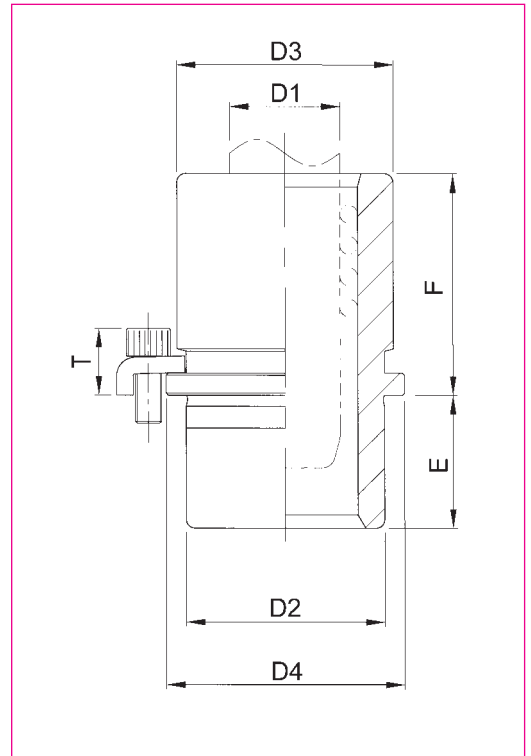
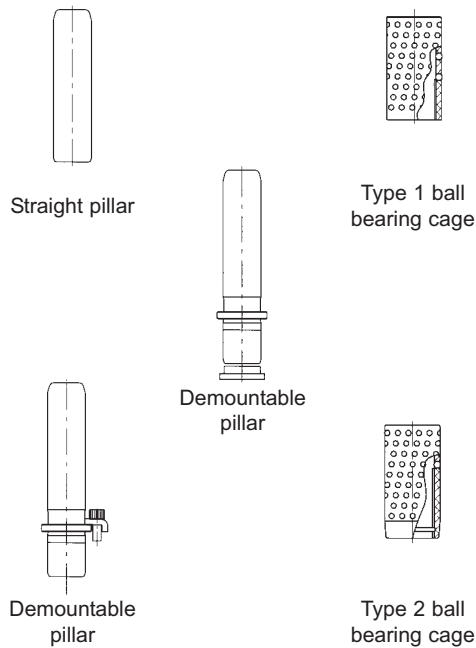

Examples

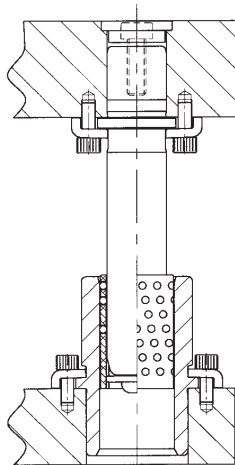
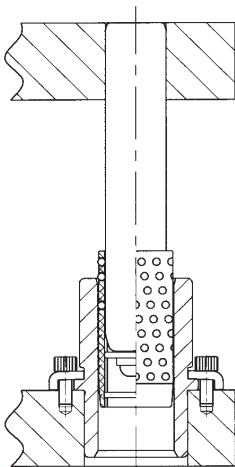

For Ø24 to 32

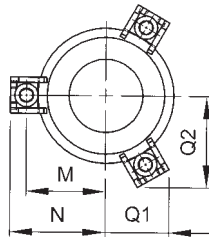

$R = D_4/2$

For Ø38 to 80

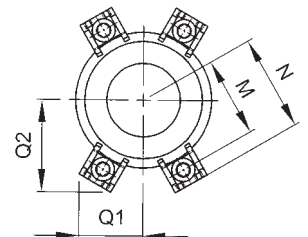

D1	24	25	30	32	38	40	48	50	63	80
F	REFERENCES									
35	B40.024.035	B40.025.035								
50	B40.024.050	B40.025.050	B40.030.050	B40.032.050	B40.038.050	B40.040.050				
65	B40.024.065	B40.025.065	B40.030.065	B40.032.065	B40.038.065	B40.040.065	B40.048.065	B40.050.065		
80			B40.030.080	B40.032.080	B40.038.080	B40.040.080	B40.048.080	B40.050.080		
100					B40.038.100	B40.040.100	B40.048.100	B40.050.100	B40.063.100	B40.080.100
120							B40.048.120	B40.050.120	B40.063.120	B40.080.120
140									B40.063.140	B40.080.140
D2	45		54		65		81		95	112
D3	49		58		70		88		103	120
D4	54		63		75		93		108	125
E			30					50		
	FIXING CLAMPS									
D1	24	25	30	32	38	40	48	50	63	80
Qty.	3		3		4		4		4	4
Ref.	B01.006.000			B01.008.000						
Screw	M6x16			M8x20						
M	31		37		43		52		60	68
N	38,2		46,3		52,3		61,3		69,3	78,7
Q1/R	26/27		30/31,5		33/37,5		37,5/46,5		41,5/54	46/62,5
Q2	37,1		44,1		49,3		57,1		64,0	71,8
T	14,7		17,5							



Case-hardened and tempered to 60 - 64 HRC

Supplied with clamps and screws.

Ordering example:

Pillar D1=30 E=32

Please state: **B42.030.042**

To be used with:



Straight pillar

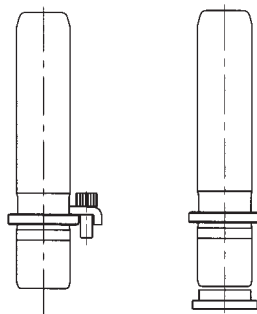

Demountable pillar

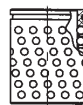

Type 3 ball bearing cage

Examples:

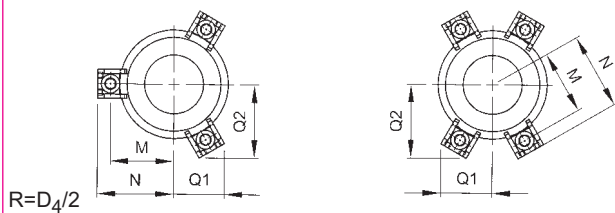
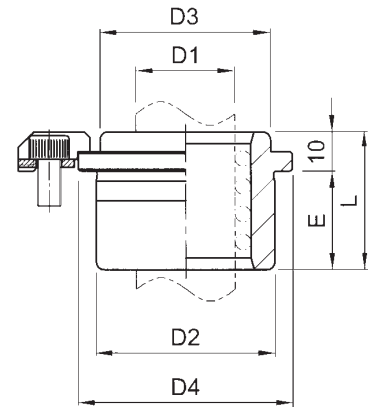
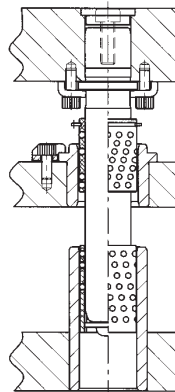
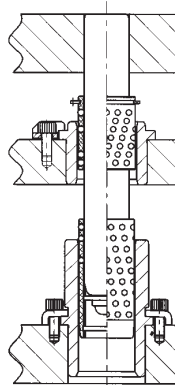

Accessories



D1	24	25	30	32	38	40	48	50
E	REFERENCE							
20	B42.024.030	B42.025.030	B42.030.030	B42.032.030				
25	B42.024.035	B42.025.035	B42.030.035	B42.032.035				
29			B42.030.039	B42.032.039	B42.038.039	B42.040.039		
32			B42.030.042	B42.032.042	B42.038.042	B42.040.042		
36					B42.038.046	B42.040.046	B42.048.046	B42.050.046
44					B42.038.054	B42.040.054	B42.048.054	B42.050.054
D2	45		54		65		81	
D3	43		50		64		79	
D4	54		63		75		93	
Clamps	B02.006.000							
Qty	3		3		4		4	
Screw	M6x12		M6x12		M6x12		M6x12	
M	33,5		38		44		53	
N	41,5		46		52,4		61	
Q1/R	26,9/27		29,2/31,5		32,2/37,5		36,7/46,5	
Q2	39,5		43,4		48,6		56,4	



TYPE 3 BALL BEARING CAGE

C13.xxx.xxx



Made from heat-treated aluminium alloy
Supplied with retaining clip.

Ordering example:

Pillar D1=30 Lc=63
Please state: **C13.030.063**

To be used with:

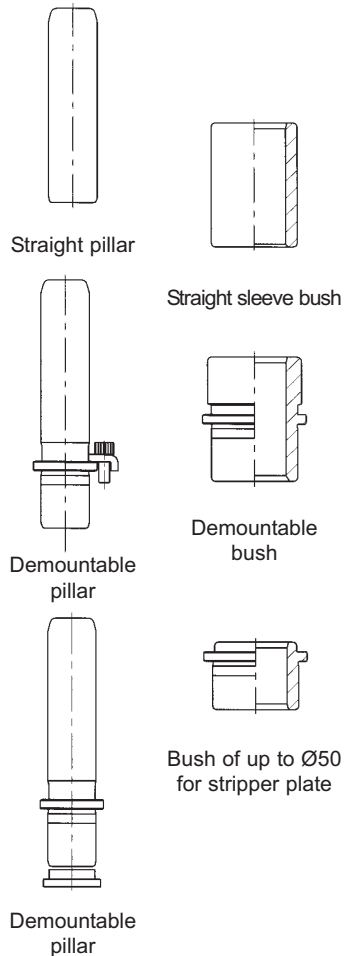

Examples:

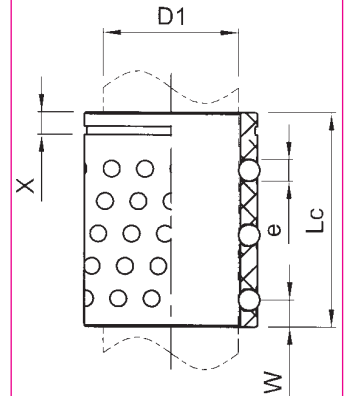
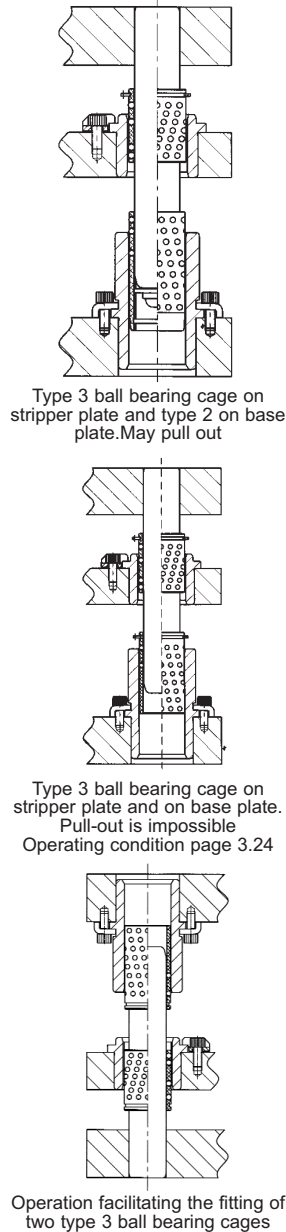

Retaining clip for type 3 ball bearing cage
C03.xxx.001

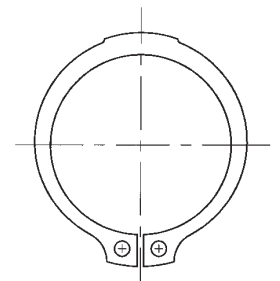

The choice of ball bearing cage for the stripper plate depends upon the guide diameter, the stroke of the stripper plate (C_i) in relation to the pillar support plate, and the depth (E) of the bushes fitted into the stripper plate. The depth (Lc) of the ball bearing cages required is determined by the following formula:

$$Lc \geq \frac{C_i}{2} + E + 10 + X$$

D1	24	25	30	32	38	40	48	50	63	80
Lc	REFERENCE									
40	C13.024.040	C13.025.040	C13.030.040	C13.032.040						
52	C13.024.052	C13.025.052	C13.030.052	C13.032.052	C13.038.052	C13.040.052				
63	C13.024.063	C13.025.063	C13.030.063	C13.032.063	C13.038.063	C13.040.063	C13.048.063	C13.050.063		
80	C13.024.080	C13.025.080	C13.030.080	C13.032.080	C13.038.080	C13.040.080	C13.048.080	C13.050.080		
100			C13.030.100	C13.032.100	C13.038.100	C13.040.100	C13.048.100	C13.050.100	C13.063.100	
125					C13.038.125	C13.040.125	C13.048.125	C13.050.125	C13.063.125	C13.080.125
140										C13.080.140
X	4,2		4,9		5,7			6,7		
e	4				6					
W	5,0		5,3		4,8			5,6		

To be used with:



Straight pillar

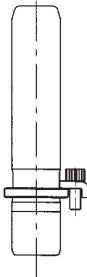

Demountable pillar

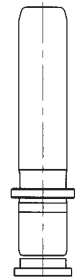

Demountable pillar



Flanged bearing bush

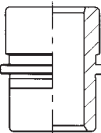

Demountable bush

Examples

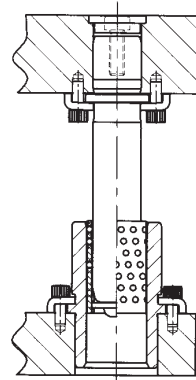

TYPE 1

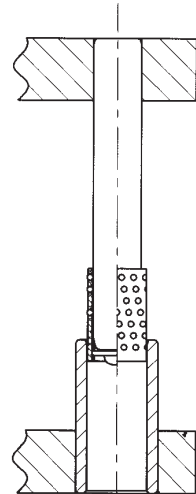

TYPE 2

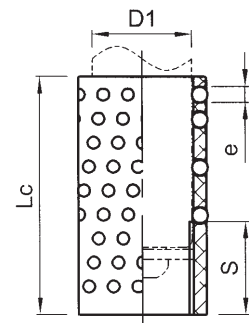

TYPE 1

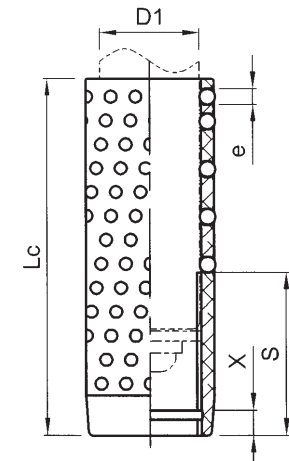

TYPE 2



Made from heat-treated aluminium alloy
Supplied with accessories.

Ordering example:

Pillar D1=30 Lc=105

Please state: C12.030.105

Type 1
Retaining accessories
C01.xxx.000

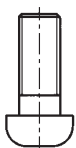
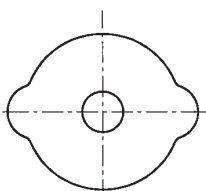

Type 2
Retaining accessories
C02.xxx.000

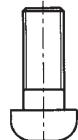
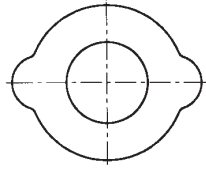
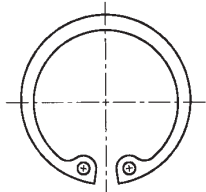

Working conditions

TYPE 1

In this case, the end of the pillar and the retaining washer may come out of the ball bearing cage. **All of the ball bearings remain precompressed** in contact with the pillar and bushes.

The cage is supplied with a washer and screw.
To select, please refer to pages 3.18 to 3.19

TYPE 2

In this case, the ball bearing cage may come out of the bush completely. At the lower end, the end of the pillar cannot leave the cage because the washer is stopped by the retaining ring.

The cage is supplied with a washer, retaining ring and screw.
To select, please refer to pages 3.20 to 3.23



TYPE 1 & 2 BALL BEARING CAGE

C11.xxx.xxx
C12.xxx.xxx

D1		24	25	30	32	38
Lc	S	TYPE 1 ball bearing cage reference				
36	11,5	C11.024.036	C11.025.036	C11.030.036	C11.032.036	
48	17,5	C11.024.048	C11.025.048	C11.030.048	C11.032.048	C11.038.048
60	23,5					C11.038.060

D1		40	48	50	63	80
Lc	S	TYPE 2 ball bearing cage reference				
55	27	C12.024.055	C12.025.055			
70	35	C12.024.070	C12.025.070	C12.030.070	C12.032.070	
	36					C12.038.070
85	43					C12.038.085
90	42	C12.024.090	C12.025.090			
	43			C12.030.090	C12.032.090	
100	50	C12.024.100	C12.025.100			
105	51			C12.030.105	C12.032.105	
	51					C12.038.105
110	60	C12.024.110	C12.025.110			
115	61			C12.030.115	C12.032.115	
	61					C12.038.115
125	70			C12.030.125	C12.032.125	
	71					C12.038.125
135	80			C12.030.135	C12.032.135	
	81					C12.038.135
145	91					C12.038.145
155	103					C12.038.155
X		4.2				5.8
e		4				

D1		40	48	50	63	80
Lc	S	TYPE 1 ball bearing cage reference				
48	17,5	C11.040.048				
60	23,5	C11.040.060				
70	28,5		C11.048.070	C11.050.070		
84	35,5		C11.048.084	C11.050.084		
98	42,5				C11.063.098	C11.080.098

D1		40	48	50	63	80
Lc	S	TYPE 2 ball bearing cage reference				
70	36	C12.040.070				
85	43	C12.040.085				
105	51	C12.040.105	C12.048.105	C12.050.105		
115	61	C12.040.115				
120			C12.048.120	C12.050.120		
125	71	C12.040.125				
135	81	C12.040.135				
140	71		C12.048.140	C12.050.140		
145	72				C12.063.145	C12.080.145
	91	C12.040.145				
150	81		C12.048.150	C12.050.150		
155	103	C12.040.155				
160	91		C12.048.160	C12.050.160		
165	82				C12.063.165	C12.080.165
170	103		C12.048.170	C12.050.170		
180	92				C12.063.180	C12.080.180
185	116		C12.048.185	C12.050.185		
190	105				C12.063.190	C12.080.190
195	128		C12.048.195	C12.050.195		
205	117				C12.063.205	C12.080.205
215	130				C12.063.215	C12.080.215
X		5.8	7.0			8.5
e		4	6			



DEMOUNTABLE ROUND OR SQUARE STEEL BLOCK

R05.xxx.xxx
R06.xxx.xxx
R07.xxx.xxx
R08.xxx.xxx

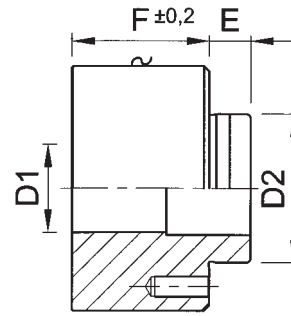
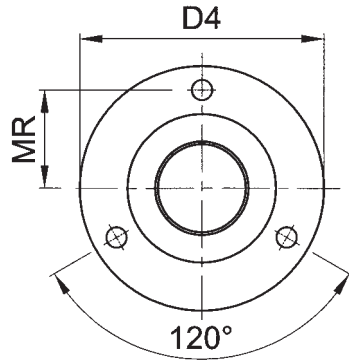

D1	32	40	50	63	80
F	REFERENCE FOR DEMOUNTABLE PILLAR STEEL BLOCK				
40	R05.032.040				
50	R05.032.040				
63		R05.040.063			
80		R05.040.080	R05.050.080		
100			R05.050.100	R05.063.100	
125				R05.063.125	R05.080.125
F	REFERENCE FOR DEMOUNTABLE BUSH STEEL BLOCK				
40	R06.032.040				
50	R06.032.040				
63		R06.040.063			
80		R06.040.080	R06.050.080		
100			R06.050.100	R06.063.100	
125				R06.063.125	R06.080.125

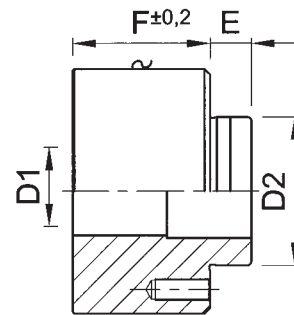
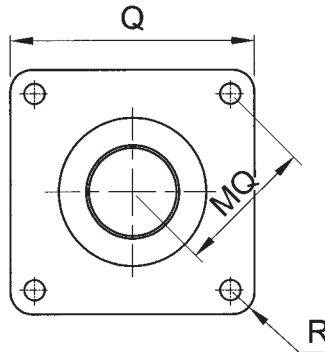

D1	32	40	50	63	80
F	REFERENCE FOR DEMOUNTABLE PILLAR STEEL BLOCK				
40	R07.032.040				
50	R07.032.040				
63		R07.040.063			
80		R07.040.080	R07.050.080		
100			R07.050.100	R07.063.100	
125				R07.063.125	R07.080.125
F	REFERENCE FOR DEMOUNTABLE BUSH STEEL BLOCK				
40	R08.032.040				
50	R08.032.040				
63		R08.040.063			
80		R08.040.080	R08.050.080		
100			R08.050.100	R08.063.100	
125				R08.063.125	R08.080.125
DIMENSIONS					
D2	54	65	81	100	118
D4=Q	89	102	114	140	165
E	15				
MR	35,75	41,75	48,75	60	70,75
MQ	48,79	55,15	59,40	77,78	88,39
Screw	M6			M8	

Fitting the demountable steel blocks

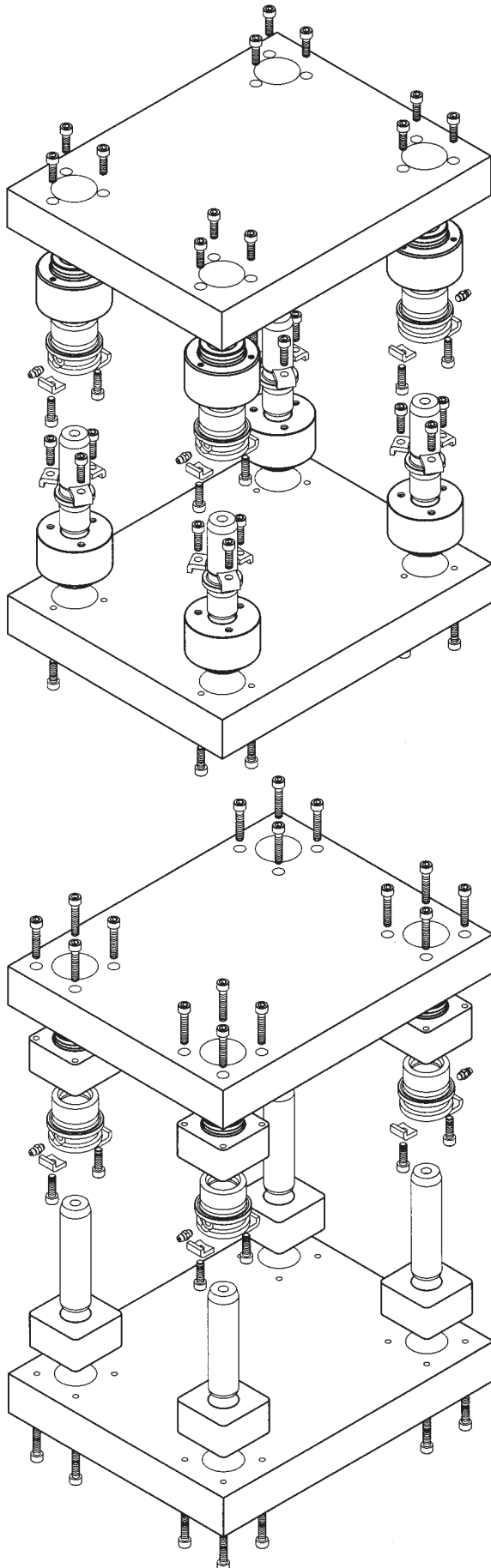

To be used with:



Straight pillar

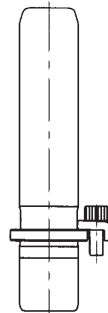

Demountable pillar

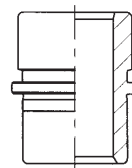

Demountable bush

Examples:

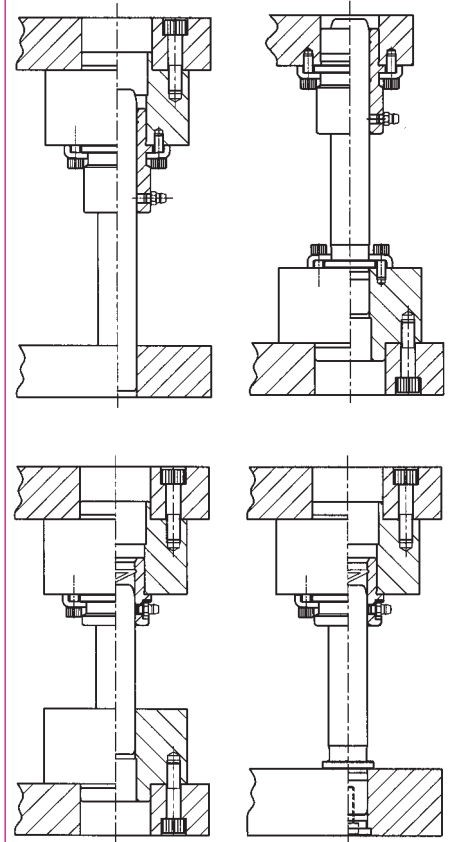

MAIN ADVANTAGES AND OBSERVATIONS

- 1- The insertion method for the demountable steel blocks allows precise positioning in the bore without using pins and offers improved overall rigidity.
- 2- The demountable steel blocks are interchangeable within the same product reference, allowing them to be swapped during dismantling and reassembly operations without affecting the performance of the tool.
- 3- They are made from rolled carbon steel in round or square sections and are available in different standard thicknesses. Intermediate thicknesses are available upon request for a price supplement.

Please note:

- Diameter D1 corresponds to the nominal diameter of the pillar.
- The screw lengths must be determined according to the thickness of the plates to which the extensions will be fitted.
- The extensions may be used with the ball bearing guide system. Please contact us for help with any of your questions.

Ordering example:

Round bush extensions; D1=40 mm; F=80 mm
Please state: **R06.040.080**

GUIDE PILLAR
P10.xxx.xxx

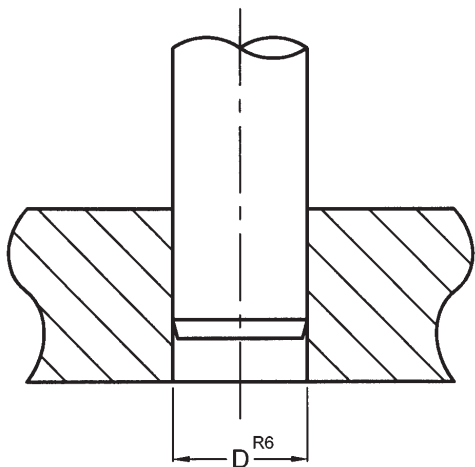

Pillar diameter D_1	Bore diameter D^{R6}	
19/20	19/20	-0,024 -0,037
24/25	24/25	-0,024 -0,037
30/32	30/32	-0,029 -0,045
38/40	38/40	-0,029 -0,045
48/50	48/50	-0,029 -0,045
63	63	-0,035 -0,054
80	80	-0,037 -0,056

DEMOUNTABLE GUIDE PILLAR
P21.xxx.xxx

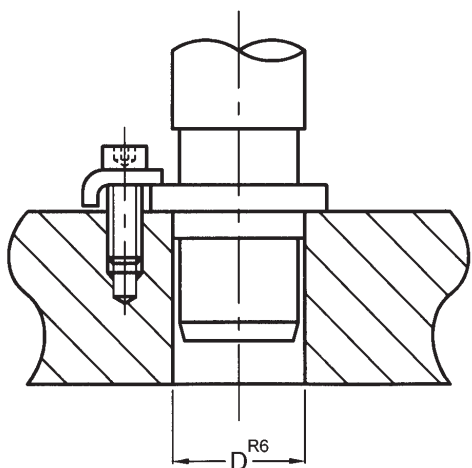

Pillar diameter D_1		Bore diameter D^{R6}		Adjustment Min. Max.
19/20	-0,011 -0,020	19/20	-0,024 -0,037	-0,004 -0,026
24/25	-0,011 -0,020	24/25	-0,024 -0,037	-0,004 -0,026
30/32	-0,016 -0,025	30/32	-0,029 -0,045	-0,004 -0,029
38/40	-0,016 -0,025	38/40	-0,029 -0,045	-0,004 -0,029
48/50	-0,017 -0,029	48/50	-0,029 -0,045	0,000 -0,028
63	-0,017 -0,029	63	-0,035 -0,054	-0,006 -0,037
80	-0,017 -0,029	80	-0,037 -0,056	-0,008 -0,039

DEMOUNTABLE GUIDE PILLAR
P22.xxx.xxx

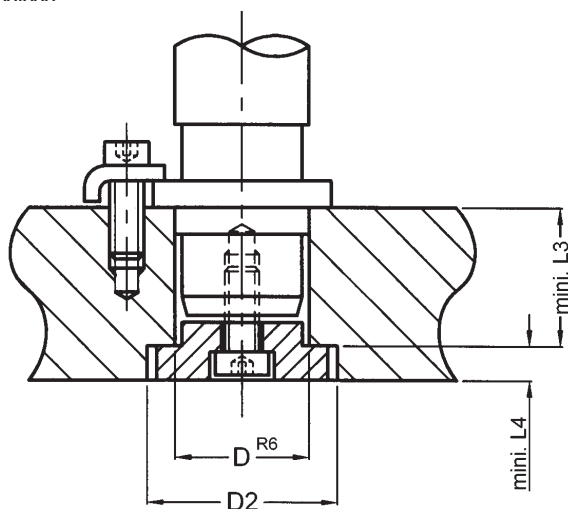

Pillar diameter D_1		Bore diameter D^{R6}		D_2	L_3	L_4
19/20	-0,011 -0,020	19/20	-0,024 -0,037	26	25	3,5
24/25	-0,011 -0,020	24/25	-0,024 -0,037	33	30	5,5
30/32	-0,016 -0,025	30/32	-0,029 -0,045	41	40	5,5
38/40	-0,016 -0,025	38/40	-0,029 -0,045	51	51	5,5
48/50	-0,017 -0,029	48/50	-0,029 -0,045	64	59	5,5
63	-0,017 -0,029	63	-0,035 -0,054	77	70	5,5
80	-0,017 -0,029	80	-0,037 -0,056	94	86	5,5

DEMOUNTABLE STEEL BUSHES B10.xxx.xxx

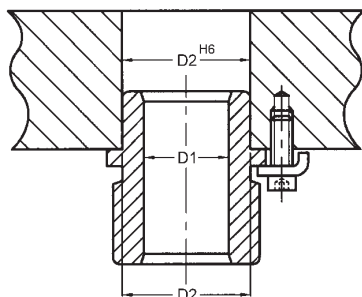

Nominal diameter D ₁	Bush diameter D ₂	Bore diameter D ₂ H ₆	Min. / max. Adjustment
19/20	28 +0,021 +0,013	28 +0,013 +0,000	-0,000 -0,021
24/25	38 +0,025 +0,016	38 +0,016 +0,000	-0,000 -0,025
30/32	45 +0,025 +0,016	45 +0,016 +0,000	-0,000 -0,025
38/40	54 +0,030 +0,019	54 +0,019 +0,000	-0,000 -0,030
48/50	65 +0,030 +0,019	65 +0,019 +0,000	-0,000 -0,030
63	81 +0,035 +0,022	81 +0,022 +0,000	-0,000 -0,035
80	100 +0,035 +0,022	100 +0,022 +0,000	-0,000 -0,035

STRAIGHT SLEEVE BALL BEARING BUSHES B30.xxx.xxx

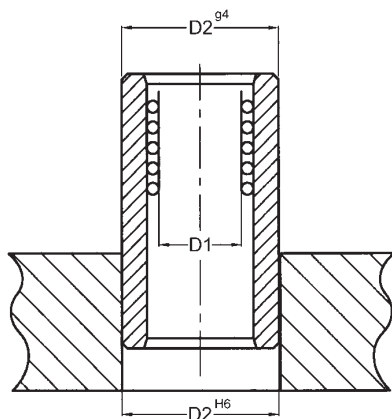

Nominal diameter D ₁	Bush diameter D ₂ g ₄	Bore diameter D ₂ H ₆	Min. / max. Adjustment
24/25	45 -0,009 -0,016	45 +0,016 +0,000	+0,009 +0,032
30/32	54 -0,010 -0,018	54 +0,019 +0,000	+0,010 +0,037
38/40	65 -0,010 -0,018	65 +0,019 +0,000	+0,010 +0,037
48/50	81 -0,012 -0,022	81 +0,022 +0,000	+0,012 +0,044
63	95 -0,012 -0,022	95 +0,022 +0,000	+0,012 +0,044
80	112 -0,012 -0,022	112 +0,022 +0,000	+0,012 +0,044

DEMOUNTABLE BALL BEARING BUSHES B40.xxx.xxx / B42.xxx.xxx

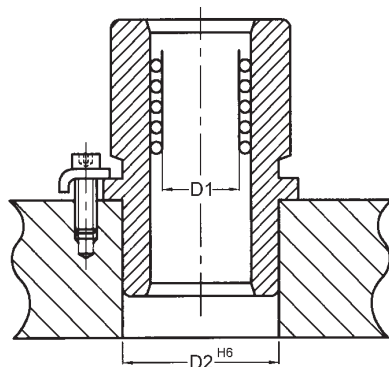

Nominal diameter D ₁	Bush diameter D ₂	Bore diameter D ₂ H ₆	Min. / max. Adjustment
24/25	45 +0,025 +0,016	45 +0,016 +0,000	-0,000 -0,025
30/32	54 +0,030 +0,019	54 +0,019 +0,000	-0,000 -0,030
38/40	65 +0,030 +0,019	65 +0,019 +0,000	-0,000 -0,030
48/50	81 +0,035 +0,022	81 +0,022 +0,000	-0,000 -0,035
63	95 +0,035 +0,022	95 +0,022 +0,000	-0,000 -0,035
80	112 +0,035 +0,022	112 +0,022 +0,000	-0,000 -0,035

PILLAR/BUSH EXTENSION R0x.xxx.xxx

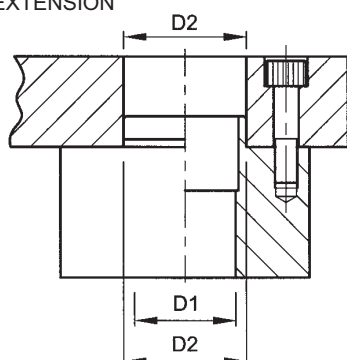

Nominal diameter D ₁	Extension diameter D ₂	Bore diameter D ₂ H ₆	Min. / max. Adjustment
32	54 +0,030 +0,019	54 +0,019 +0,000	-0,000 -0,025
40	65 +0,030 +0,019	65 +0,019 +0,000	-0,000 -0,030
50	81 +0,035 +0,022	81 +0,022 +0,000	-0,000 -0,035
63	100 +0,035 +0,022	100 +0,022 +0,000	-0,000 -0,035
80	118 +0,035 +0,022	118 +0,022 +0,000	-0,000 -0,035

TYPE 1: The cage is completely preloaded throughout the entire stroke

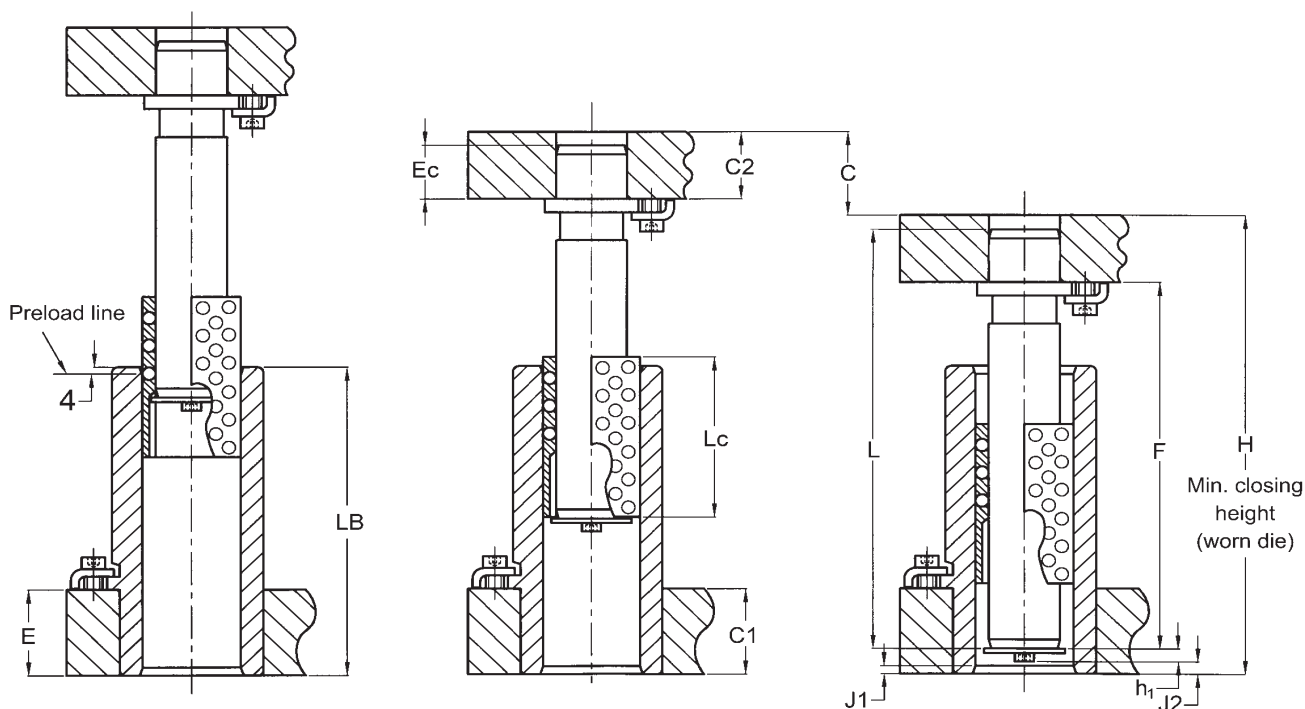

Unit in the assembly position: Ball bearing cage suspended on the tabs of the retaining washer.

Unit at the top of the stroke position.

Unit at the bottom of the stroke.

Calculating the length of the pillars

- Use of B30.xxx.xxx bush

$$L \text{ pillar, type P10} = H - h_1 - J_2 - C_2 + E_c$$

$$F \text{ pillar, type P21} = H - h_1 - J_2 - C_2$$

- Use of B40.xxx.xxx bush

$$L \text{ pillar, type P10} = H - h_1 - J_1 - C_1 + E - C_2 + E_c$$

$$F \text{ pillar, type P21} = H - h_1 - J_1 - C_1 + E - C_2$$

- H = Min. closing height
- h₁ = Height of nut + washer at base of pillar
- J₂ = Safety margin at end of stroke (B30 bush)
- C₂ = Thickness of top plate
- E_c = Depth of insertion for straight pillar
- J₁ = Safety margin at end of stroke (B40 flanged bearing bush)
- C₁ = Thickness of bottom plate
- E = Depth of insertion for B40 bush

Refer to page 3.23 for values E, h, J₁ and J₂

The choice of a Type 1 bushing and ball cage unit is based upon the required stroke and the nominal diameter of the pillar.

When these two measurements are known, choose the components by referring to the table opposite.

- Choose the required stroke from the “Stroke C” column.
- Follow this column down until you come to the coloured box situated in the row corresponding to the required pillar diameter.
- You will find the required length of bush on the same row, in column L_B.
- Choose the required length of ball bearing cage from column L_C. The longer the ball bearing cage, the longer its life span. Verify that the die closing height allows for this choice
- See above to calculate the pillar lengths.



BUSHING & BALL CAGE SELECTION CHART - TYPE 1

Nominal pillar dia.	Bush length	Cage length	Stroke C (worn die and punch)			
			10	50	100	150
D_n	L_B	L_C				
24/25	65	36	█	█		
	80		█	█		
	95	█	█			
	110	█	█	█		
	130	48	█	█	█	█
150	█		█	█	█	
30/32	80	36	█	█		
	95		█	█		
	110	█	█	█		
	130	█	█	█	█	
	150	48	█	█	█	█
170	█		█	█	█	
38/40	80	48	█	█		
	95		█	█		
	110	█	█	█		
	130	█	█	█	█	
	150	█	█	█	█	
	170	█	█	█	█	
	190	60	█	█	█	█
215	█		█	█	█	
48/50	110	70	█	█		
	130		█	█		
	150	█	█	█		
	170	█	█	█	█	
	190	█	█	█	█	
	215	84	█	█	█	█
	240		█	█	█	█
265	█		█	█	█	
63	150	98	█	█		
	170		█	█		
	190	█	█	█		
	215	█	█	█	█	
	240	█	█	█	█	
80	150	98	█	█		
	170		█	█		
	190	█	█	█		
	215	█	█	█	█	
	240	█	█	█	█	

TYPE 2: The ball bearing cage is no longer preloaded

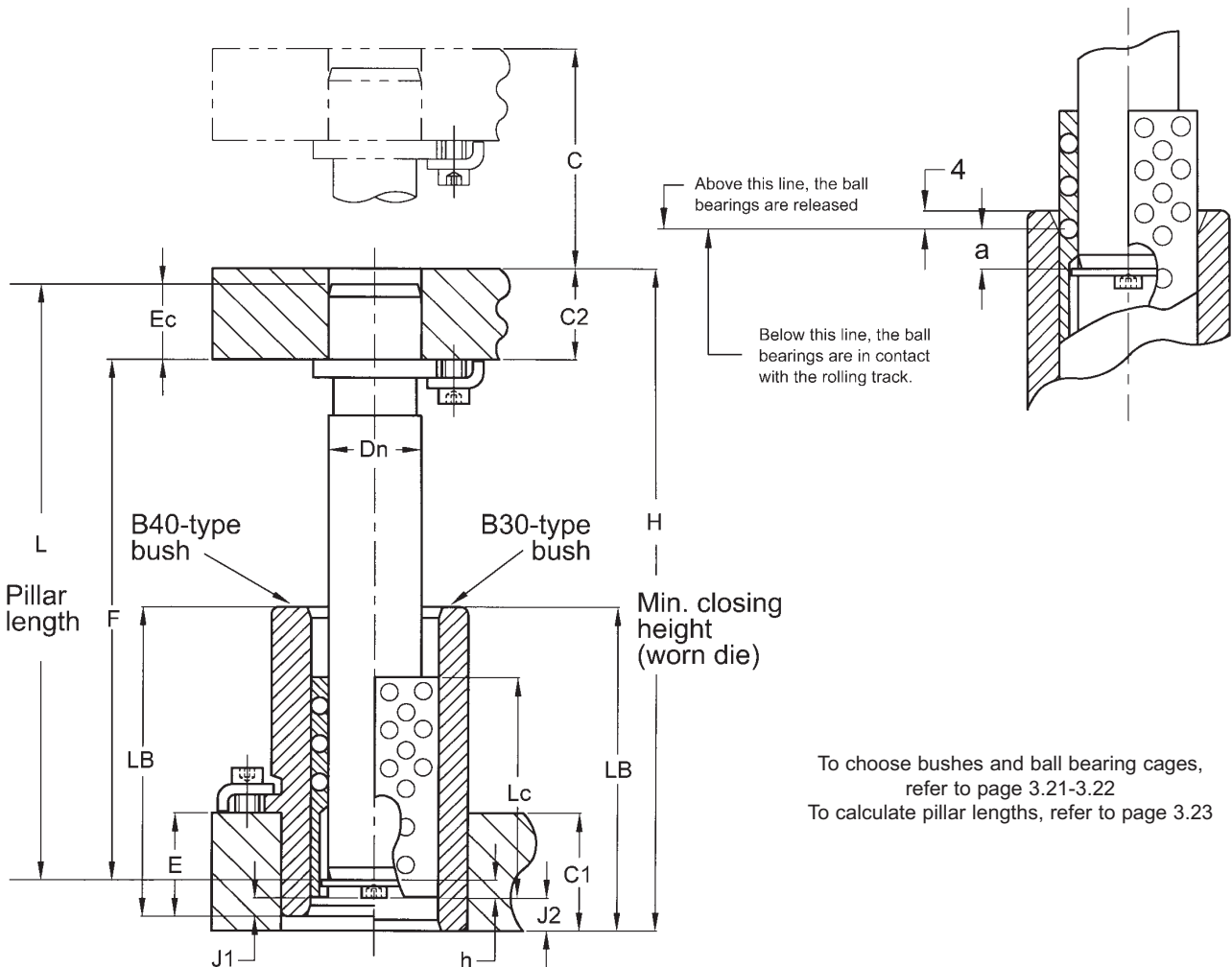
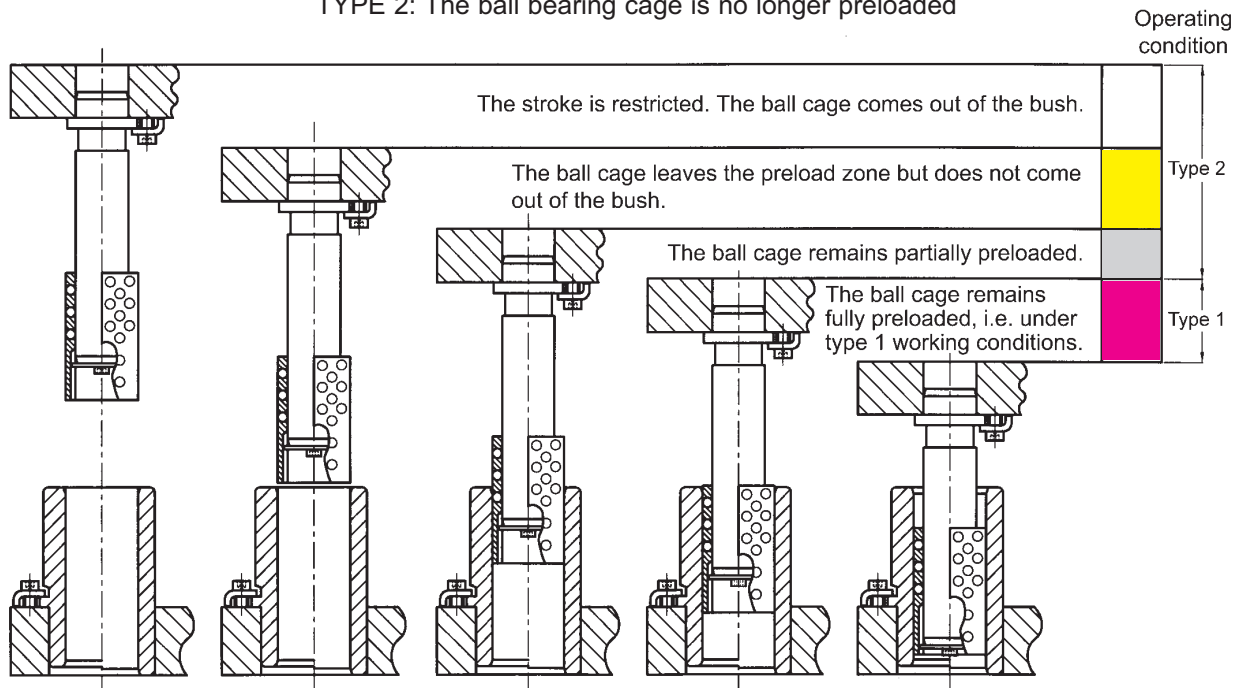

To choose bushes and ball bearing cages,
refer to page 3.21-3.22
To calculate pillar lengths, refer to page 3.23

Nominal pillar diameter	Bush						Length of ball cage	Stroke C at m			
	Demountable B40.xxx.xxx			Straight B30.xxx.xxx				10	50	100	150
D _n	E	F	L _B	J ₁	L _B	J ₂	L _C				
24/25	30	35	65	4	65	4	55	█	█	█	█
		50	80	4	80	4	70	█	█	█	█
		65	95	4	95	4	90	█	█	█	█
					110	4	100	█	█	█	█
					130	4	110	█	█	█	█
30/32	30	50	80	4	80	4	70	█	█	█	█
		65	95	4	95	4	90	█	█	█	█
		80	110	4	110	4	105	█	█	█	█
					130	4	115	█	█	█	█
					150	4	125	█	█	█	█
38/40	30	50	80	4	80	4	70	█	█	█	█
		65	95	4	95	4	85	█	█	█	█
		80	110	4	110	4	105	█	█	█	█
		100	130	4	130	4	115	█	█	█	█
					150	4	125	█	█	█	█
					170	4	135	█	█	█	█
					190	4	145	█	█	█	█
48/50	50	65	115	4	110	4	105	█	█	█	█
		80	130	4	130	4	120	█	█	█	█
		100	150	4	150	4	140	█	█	█	█
		120	170	4	170	4	150	█	█	█	█
					190	4	160	█	█	█	█
					215	4	170	█	█	█	█
					240	4	185	█	█	█	█
63	50	100	150	4	150	4	145	█	█	█	█
		120	170	4	170	4	165	█	█	█	█
		140	190	4	190	4	180	█	█	█	█
					215	4	190	█	█	█	█
					240	4	205	█	█	█	█
					265	4	215	█	█	█	█
80	50	100	150	4	150	4	145	█	█	█	█
		120	170	4	170	4	165	█	█	█	█
		140	190	4	190	4	180	█	█	█	█
					215	4	190	█	█	█	█
					240	4	205	█	█	█	█
					265	4	215	█	█	█	█

SELECTION CHART - TYPE 2

Minimum closing height (worn die)

200

250

300

350

400

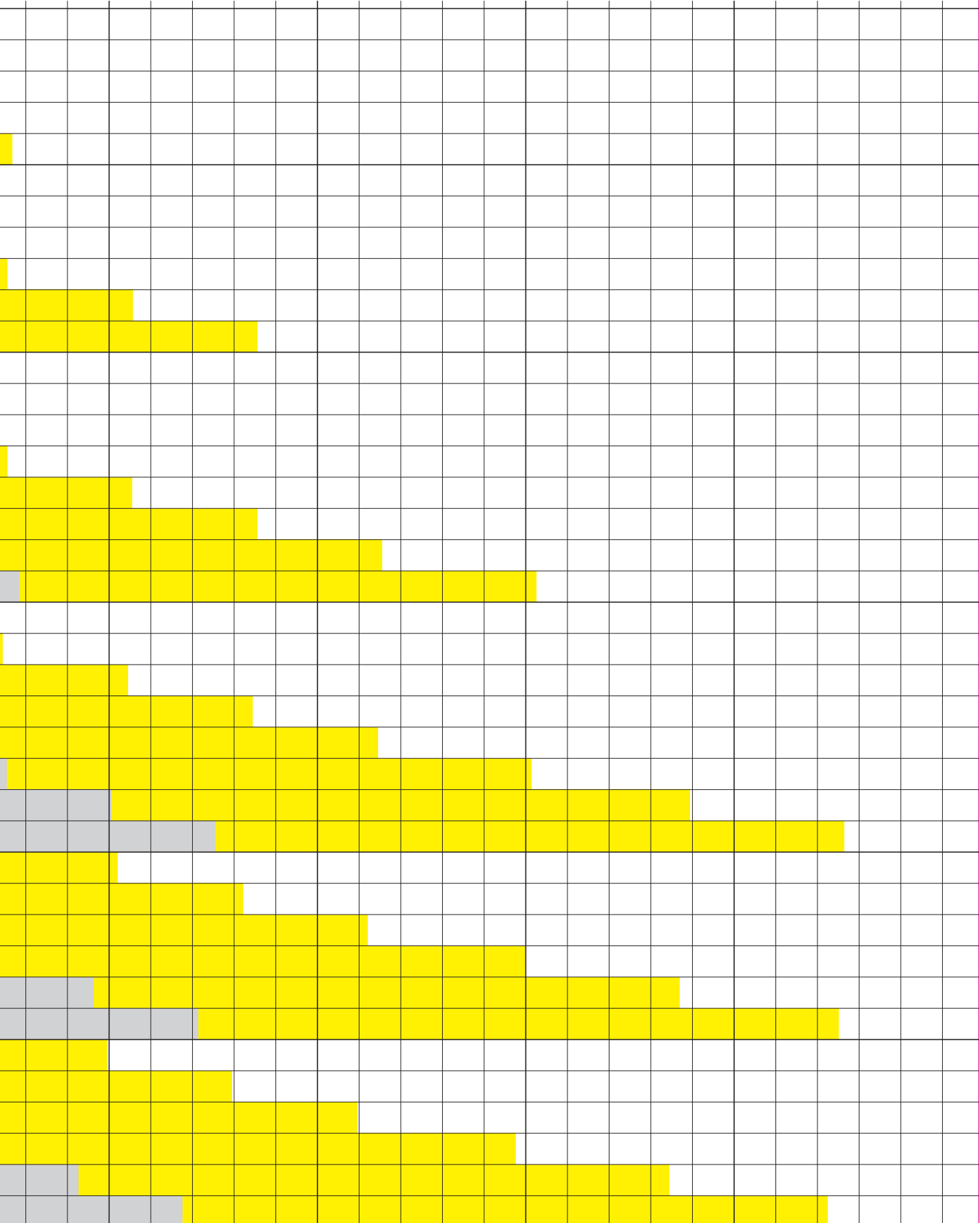

Calculating the pillar length

- Use of bush B30.xxx.xxx
 - L pillar type P10 = $H - h_2 - J_2 - C_2 + E_c$
 - F pillar type P21 = $H - h_2 - J_2 - C_2$
- Use of bush B40.xxx.xxx
 - L pillar type P10 = $H - h_2 - J_1 - C_1 + E - C_2 + E_c$
 - F pillar type P21 = $H - h_2 - J_1 - C_1 + E - C_2$

If the correct length of guide pillar does not exist:

For the P10 type: - Choose a guide pillar of next length up and cut it down to length L, or
- Choose a guide pillar of the next shortest length and place it in the punch plate in such a way that you obtain length L

For the P21 type: - Adjust the dimension C_2 in order to obtain J_2 and h_2 at the lowest point.

For the P22 type: - Position bush B30 in order to obtain J_2 and h at the lowest point.

- H = Min. closing height
- h_2 = Height of nut + washer at base of pillar
- J_2 = Safety margin at end of stroke (B30 bush)
- C_2 = Thickness of top plate
- E_c = Depth of insertion for straight pillar
- J_1 = Safety margin at end of stroke (B40 flanged bearing bush)
- C_1 = Thickness of bottom plate
- E = Depth of insertion for B40 bush

To choose a type 2 ball bearing bushing unit, you must first determine the required length of stroke C, and the diameter of the pillar. Next, determine the operating conditions (see pages 3.18 to 3.22).

When these three factors are known, refer to the selection table on pages 3.21 and 3.22. Go to the column with the stroke C required. Follow this column down until you are level with the required diameter D_n and find the box corresponding to the desired operating conditions.

The longest ball bearing bush allowed by the closing height will have the longest service life.

When you have found the corresponding coloured box, follow the horizontal line towards the right-hand side to select the correct lengths of bush and ball bearing cage. See the previous page to calculate the pillar length.

When you have determined all of these measurements, refer to the pages giving all of the dimensions and reference numbers for the different parts.

Nominal pillar \varnothing D_n	a	h_1	h_2	$J_1=J_2$	E
24/25	14,5	5,8	9,3	4	30
30/32	14	6,9	10,4	4	30
38/40	14,5	8	11,5	4	30
48/50	15,5	9,1	12,6	4	50
63	15,5	12,5	16	4	50
80	15,5	15	18,5	4	50

TYPE 3: Part of the ball bearing cage is permanently preloaded during the entire working stroke.

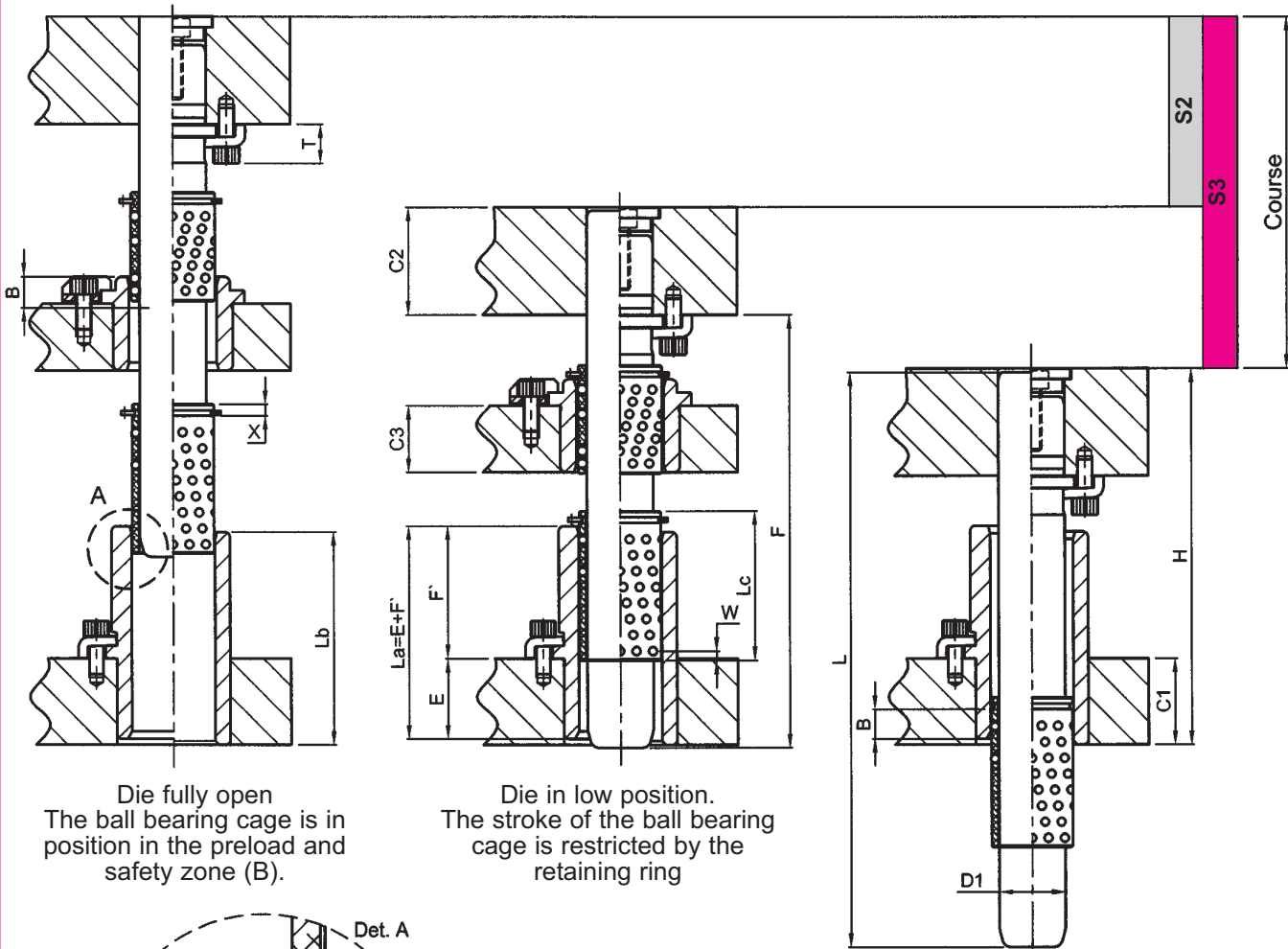

Die fully open
The ball bearing cage is in position in the preload and safety zone (B).

Die in low position.
The stroke of the ball bearing cage is restricted by the retaining ring

Die in maximum position.
Die with ball bearing cage without retaining ring and without stripper plate.

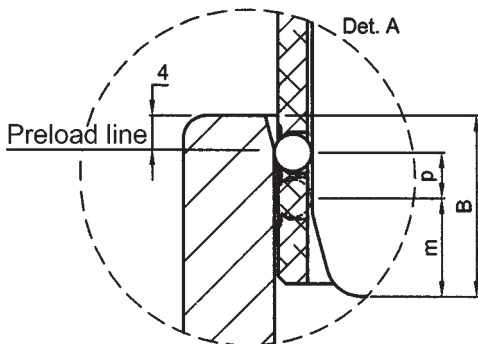

Calculation of strokes S2 and S3 with type 3 ball bearing cage.

$S2 = 2 (Lc - X - W - B)$

$S3 = (Lc - X - W + La \text{ or } Lb) - 4 (B)$

- H = Min. closing height
- La = Length of demountable bush (type B4x.xxx.xxx)
- Lb = Length of demountable bush (type B30.xxx.xxx)
- Lc = Length of ball bearing cage (type C13.xxx.xxx)
- p = Pitch of rows of ball bearings (ball bearing cage type C13.xxx.xxx)
- m = Entry taper of pillar
- B = Safety height for bearings when preloaded

Technical data:

- Values La, E and F': See pages 3.09 and 3.10
- Lb values : See page 3.08
- Lc values : See page 3.11

D1	24	25	30	32	38	40	48	50	63	80
X	4,2		4,9			5,7			6,7	
W	5		5,3			4,8			5,6	
B		20,1			21,1		22,8		23,6	24,8

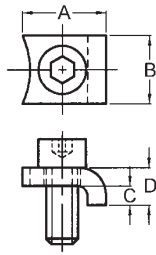

B01.00x.000

Clamps (without screws)

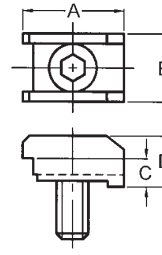

B02.00x.000

Ref.	B01.005.000	B01.006.000	B01.008.000	B02.006.000	B02.008.000
A	12,3	14,3	19,8	18,3	24,6
B	12,7	15,9	15,9	14,5	18,8
C	3,2	4,9	4,9	5	5
D	5,6	8,7	9,5	10	13
Ø screw	M5	M6	M8	M6	M8

Retaining rings for P22.xxx.xxx demountable pillars

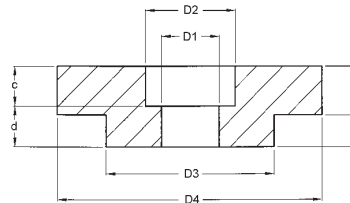

Nominal pillar Ø Dn	19	20	24	25	30	32	38	40	48	50	63	80
D1	5,6		6,8		8,8		10,8		12,8		17	21
D2	9,7		11,2		14,2		17,2		19,2		25,5	31,5
D3	19		24		30		38		48		63	80
D4	25		32		40		50		63		76	93
a	3,3		5		5		5		5		5	5
b	4,2		4		7		10		13		19	25
c	5		6		8		10		12		16	20
d	2,5		3		4		5		6		8	10
Ref.	P02.020.000		P02.025.000		P02.032.000		P02.040.000		P02.050.000		P02.063.000	P02.080.000

	Retaining washer TYPE 1	Retaining washer TYPE 2	Lockwasher TYPE 2	Mounting screw ISO 7380 for Ø 24 to 50 DIN 7984 for Ø 63	TYPE 2 retaining rings:	TYPE 3 retaining rings:
Nominal pillar Ø Dn	TO BE USED FOR SETS					
	TYPE 1	TYPE 2	TYPE 2	TYPE 1 - 2	TYPE 2	TYPE 3
24	C01.024.001	C02.024.001	C02.025.002	M 6 x 20	C02.024.003	C03.024.032
25	C01.025.001	C02.025.001			C02.025.003	C03.025.033
30	C01.030.001	C02.030.001	C02.032.002	M 8 x 20	C02.030.003	C03.030.038
32	C01.032.001	C02.032.001			C02.032.003	C03.032.040
38	C01.038.001	C02.038.001	C02.040.002	M 10 x 25	C02.038.003	C03.038.046
40	C01.040.001	C02.040.001			C02.040.003	C03.040.048
48	C01.048.001	C02.048.001	C02.050.002	M 12 x 30	C02.048.003	C03.048.060
50	C01.050.001	C02.050.001			C02.050.003	C03.050.062
63	C01.063.001	C02.063.001	C02.063.002	M 16 x 35	C02.063.003	C03.063.001
80	C01.080.001	C02.080.001	C02.080.002	M 20 x 40	C02.080.003	C03.080.091



FRANCE

MDL
Rue de l'Oberwald
68360 SOULTZ
✉ BP 126 - 68503 GUEBWILLER CEDEX
Tél. : +33 (0)3 89 74 24 24
Fax : +33 (0)3 89 76 49 99
E-Mail : mdl-rodiss@mdl-rodiss.com

PORTER-BESSON S.A.S
Zone Eurespace - 5 rue Nosières
25770 SERRE LES SAPINS
✉ BP 20 - 25770 FRANOIS
Tél. : +33 (0)3 81 58 95 00
Fax : +33 (0)3 81 58 95 09
E-Mail : porter-besson@mdl-rodiss.com

GERMANY

MDL - Rodis GmbH
Verkaufsbüro
Mitscherlichstrasse 8
D-79108 FREIBURG i.B.
Tel. : +49 (0)761 503127 11
Fax : +49 (0)761 503127 68
E-Mail : mdl-verkauf@mdl-rodiss.com

BRAZIL

MÁQUINAS DANLY LTDA
Av. Prink, No. 151
CEP 18120-000 MAIRINQUE, SP
Tél. : +55 11 2107 0400
Fax : +55 11 2107 0405
E-Mail : vendasp@mdl-danly.com.br

MEXICO

MDL DE MEXICO SA DE CV
Conjunto Victoria II
Acceso III No 52 Bodega 19
Zona Industrial Benito Juarez
CP 76120 QUERETARO
Tél. : +52 442 210 0020
Fax : +52 442 210 0012
E-Mail : ventas@mdlmexico.com.mx

U.S.A.

Mold & Die Components Inc.
4520 Progress Dr.
Columbus, IN 47201
Tél. : (812) 373-0021
Fax : (812) 373-0042
E-Mail : sales@mdlusa.com